

4

3

2

1

THIS DRAWING IS UNPUBLISHED. RELEASED FOR PUBLICATION ,19 .  
 © COPYRIGHT 19 BY AMP INCORPORATED. ALL RIGHTS RESERVED.

LOC	DIST	REVISIONS			
P	LTR	DESCRIPTION	DATE	DWN	APVD
G	14	F	REDRAWN PER 0720-0470-95	23JAN95	LO ME

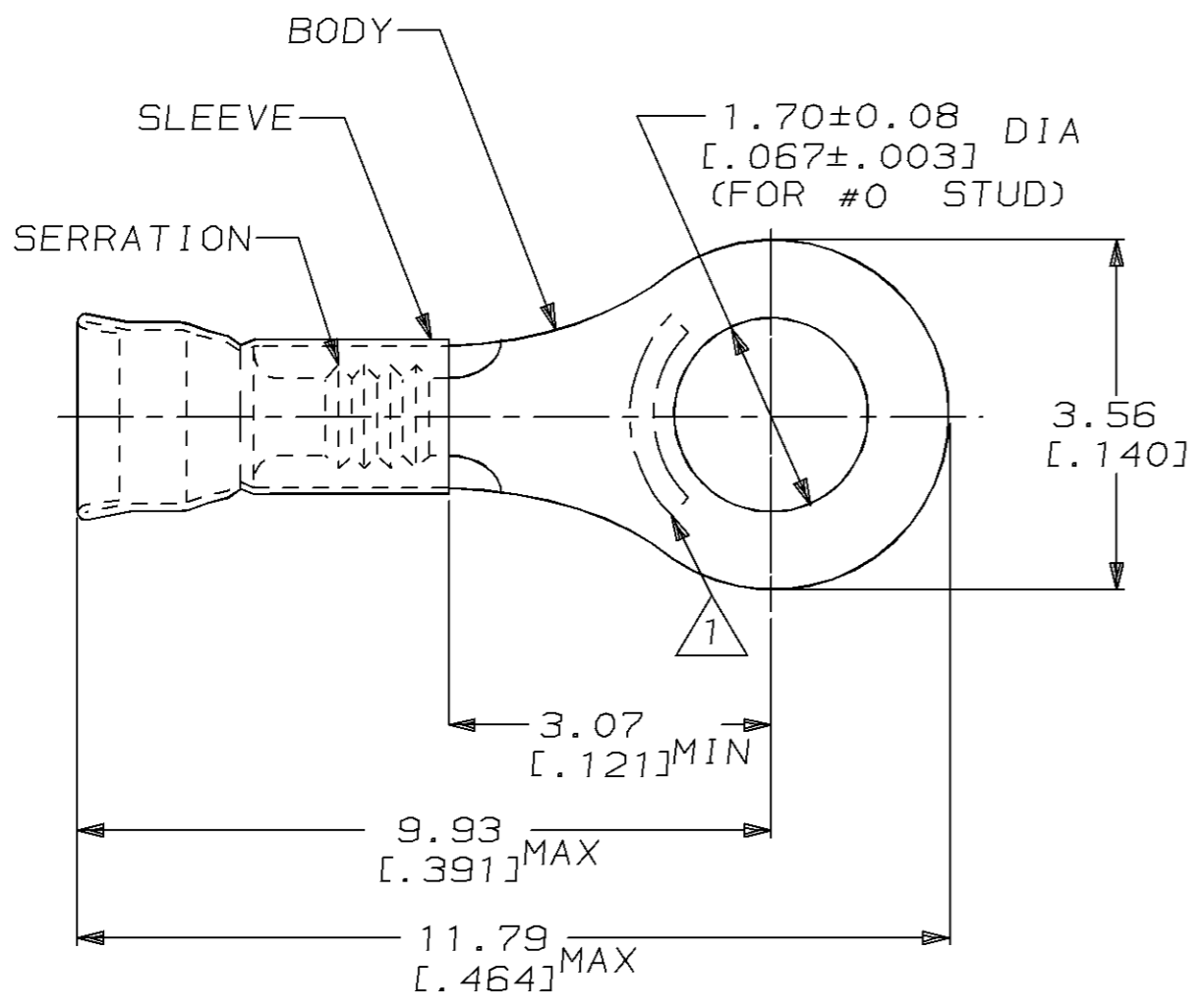

△ STAMP AMP LOCATE APPROX AS SHOWN

- WIRE INSUL DIA, 1.27-2.08 [ $.050-.082$ ]
- TONGUE MATL THK, 0.46±0.05 [ $.018±.002$ ]

1000	LOOSE PIECE	31516
QTY	PACKAGE TYPE	PART NO

AMP INCORPORATED CUSTOMER SERVICE SYSTEM		MAX RECOMMENDED OPERATING TEMPERATURE: -		THIS DRAWING IS A CONTROLLED DOCUMENT FOR AMP INCORPORATED. IT IS SUBJECT TO CHANGE AND THE CONTROLLING ENGINEERING ORGANIZATION SHOULD BE CONTACTED FOR THE LATEST REVISION.		DWN L OLMEDA 23JAN95		AMP Incorporated	
FOR ADDITIONAL PRODUCT INFORMATION OR COPIES OF DRAWINGS AND TECHNICAL DOCUMENTS		PRODUCT INFORMATION CENTER 1-800-522-6752		DIMENSIONS: mm [in]		TOLERANCES UNLESS OTHERWISE SPECIFIED:		Harrisburg, PA 17105-3608	
FOR APPLICATION TOOLING INFORMATION		TOOLING ASSISTANCE CENTER 1-800-722-1111		VOLTAGE RATING: -		0 PLC ±- 1 PLC ±- 2 PLC ±0.20 [.008] 3 PLC ±- 4 PLC ±- ANGLES ±-		NAME TERMINAL, RING, DIAMOND GRIP, WIRE SIZE, 26-22 AWG	
FOR ORDER ENTRY		1-800-526-5142		CIRCULAR MIL AREA: 0.10mm <sup>2</sup> -0.41mm <sup>2</sup> [202-810]		MATERIAL BODY, CU, SLV, CU PER ASTM B152		DRAWING NO C-31516	
		STRANDED WIRE		FINISH TIN PLATE PER MIL-T-10727		WEIGHT -		SIZE A3 CAGE CODE 00779	
						CUSTOMER DRAWING		SCALE 10:1 SHEET 1 OF 1 REV F	

AMP 1470-19 REV 09MAY94